

# *Engineering Analysis & Design*

---

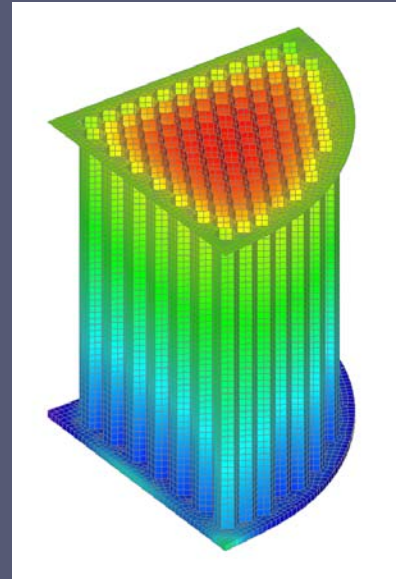

Wet Electrostatic Precipitator - Temperature, Thermal Stress, & Thermal Expansion

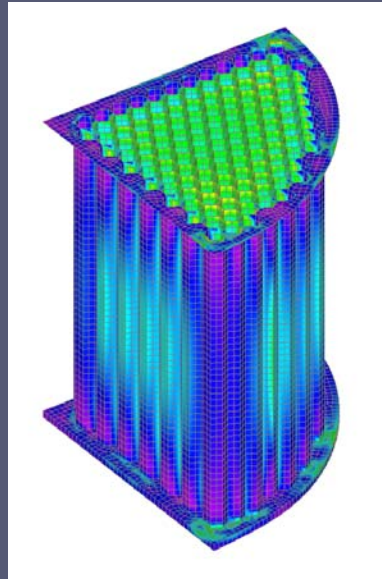
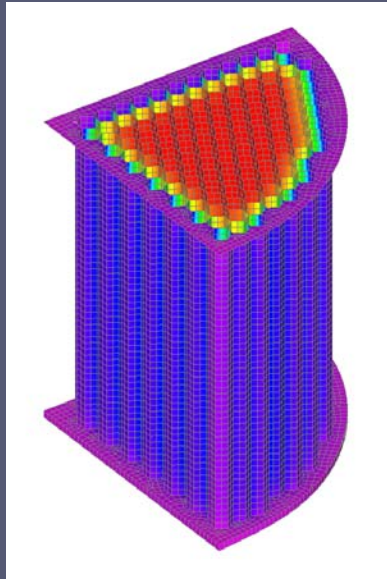
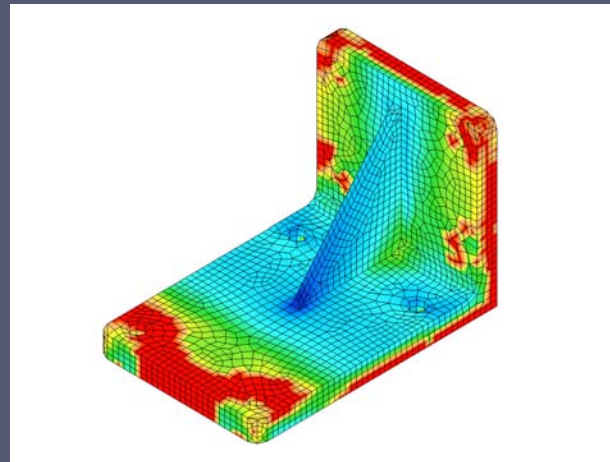
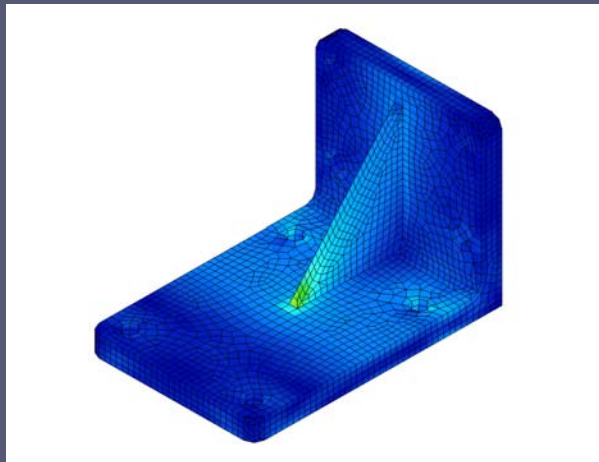

Bracket - Stress & Fatigue Life Analysis

---

*DeepSoft, Inc.*

# Engineering Analysis

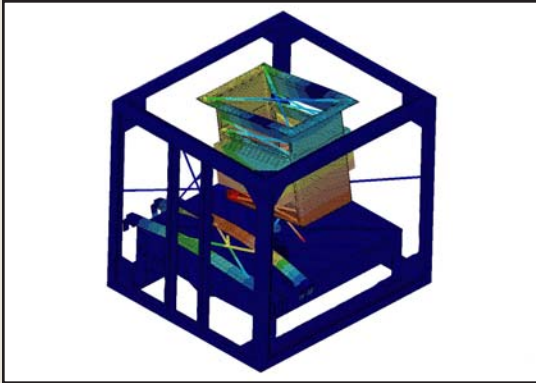

Ultrasonic Cleaner - Modal Analysis

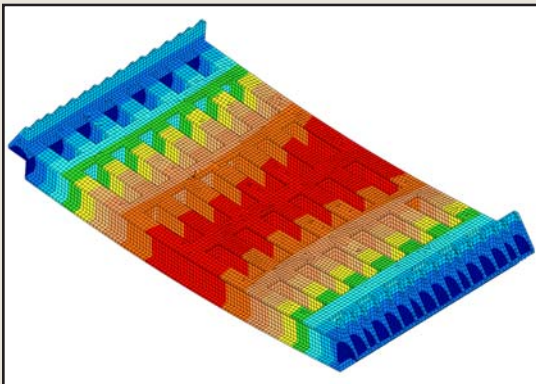

Nuclear Waste Melter Base - Displacement

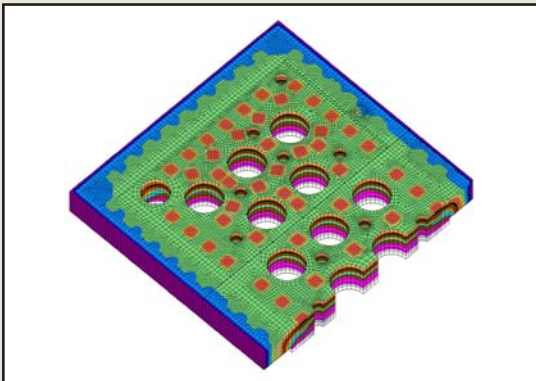

Nuclear Waste Melter Lid - Temperature

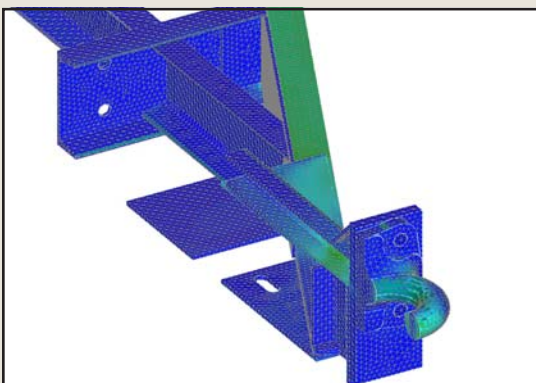

Tow Bar - Dynamic Impact Stress

## *Engineering Analysis & Design*

TurboSonic, Inc., retained DeepSoft, Inc. (DSI) to provide a detailed Nastran Finite Element Analysis (FEA) of their Wet Electrostatic Precipitators which are shown on the cover. Analyses included heat transfer, thermal expansion & stress, buckling, and structural stress. For Duratek, Inc.'s nuclear waste vitrification melter Algor FEA analyses included heat transfer, thermal expansion and stress, structural stress, and coolant loop pressure drop. Battelle Laboratories required a dynamic modal FEA to determine resonant frequencies, and a dynamic drop impact analysis of their portable ultrasonic cleaner developed for the US Army. For DHS Systems DSI performed a FEA dynamic impact stress analysis of their tow bar for a US Army trailer.

Some projects may be best served by manual calculations alone without a FEA. Preparation for FEA may involve 20-30 pages of fluid dynamic, thermodynamic, heat transfer, and structural calculations to determine loads, boundary conditions, concentrated mass, and material properties. These are typically automated with Mathcad, Excel, or a C/C++ computer program.

Stone Aerospace, developer of the Endurance Autonomous Underwater Vehicle (AUV), retained DSI to create 3D SolidWorks parts, assemblies, and drawings of their science package winch design for a series of Antarctic dives. Inventor or SolidWorks are used for new designs - SpaceClaim allows importing almost any 3D model geometry for design changes or FEA preparation. The principal has also designed a diver propulsion vehicle and a diver's decompression computer. Ocean Engineering, an interdisciplinary field, is a specialized layer of training built on top of traditional Mechanical, Electrical, and Software Engineering. Think of it as "wet" Mechatronics.

## *Engineering Tools*

- Nei Nastran & Femap FEA
- Algor & Fempro FEA
- Algor Mechanical Event Simulation FEA
- FatigueWizard for fatigue analysis
- Mathcad & Excel
- Inventor Professional
- SolidWorks
- SpaceClaim
- Mechanical Desktop
- AutoCAD
- Custom C/C++ analysis & design programs

## *Applications*

- Design and analyze virtual products
- Create more innovative and technically enhanced products
- Reduce the number of physical prototypes and tests
- Reduce product cost and time to market
- Improve marketing and customer satisfaction
- Increase product quality
- Increase automation from Art to Part
- Increase automation with custom C/C++ programs
- Reverse engineering from 3D laser scans of old parts
- Rapid prototyping of new parts
- Aid to certification or design approval

## *Finite Element Analysis*

### Linear

- Static stress & deflection
- Dynamic stress & deflection
- Buckling

### Thermal

- Steady state heat transfer
- Transient heat transfer
- Thermal expansion & stress

### Dynamics

- Modal analysis - resonant frequencies
- Drop impact - quasi static
- Drop impact - nonlinear response
- Time step - modal superposition
- Time step - direct integration
- Response analysis - frequency response
- Response analysis - random vibration
- Response analysis - response spectrum
- Fatigue life analysis

### Nonlinear

- Geometric nonlinearity
- Material nonlinearity
- Contact nonlinearity
- Mechanical Event Simulation

## *Software Training Courses*

- AutoCAD
- Inventor
- Algor FEA
- C/C++ programming
- See online course descriptions at [DeepSoftInc.com](http://DeepSoftInc.com)

## *Depth of Experience*

When it comes to CAD, CAE 3D solid modelers, FEA, and creating custom C/C++ programs to support these activities Ted Fryberger, the president of DeepSoft, Inc., is one of the most experienced engineers in the country. He began using AutoCAD in 1984, Algor FEA in 1988, and 3D solid modelers in 1999. Nastran FEA, Algor nonlinear FEA, and FatigueWizard were added in 2004. C programming began in 1984 and C++ in 1991. He has been a member of the Autodesk Developer Network (ADN) for over twenty years, currently focusing on custom ObjectARX C++ AutoCAD and Inventor applications. For eight years he taught all of the onsite C & C++ programming courses at NASA's Goddard Space Flight Center to engineers, programmers, and scientists.

## *Innovate, Automate, Educate, or Evaporate*

In this intensely competitive global market, DeepSoft, Inc. can assist you with developing new and more innovative products, improving quality, automating your workflow, reducing time to market, and training your staff.

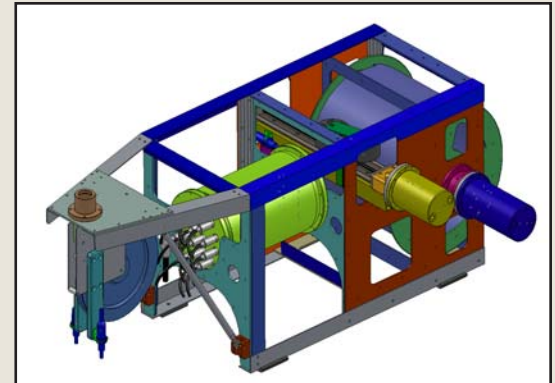

Endurance AUV Winch

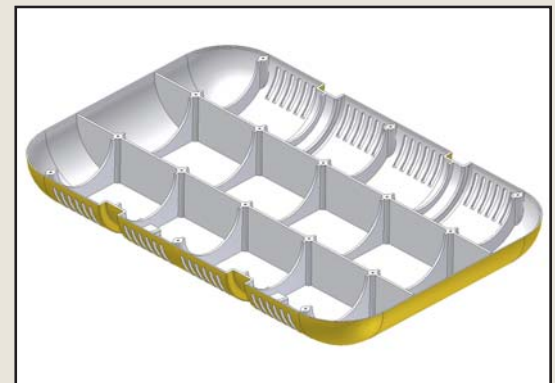

Hydrodynamic Fairing

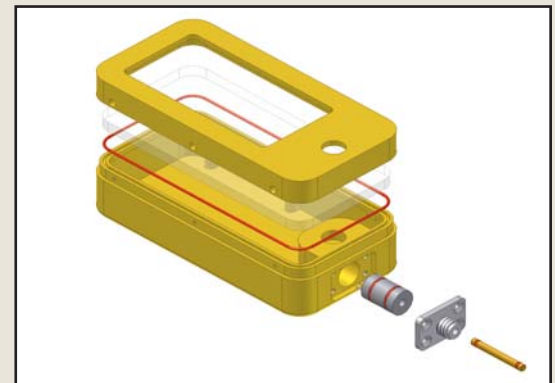

Instrument Case

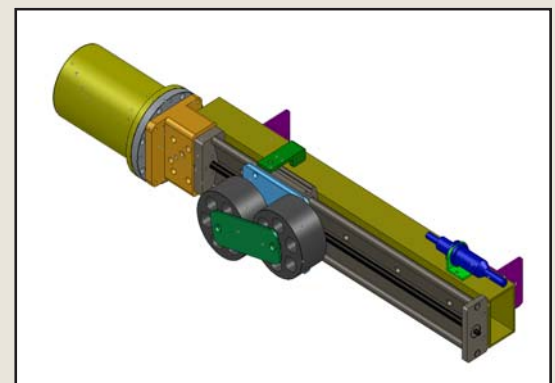

Endurance AUV

DeepSoft, Inc. is an independent consulting engineering firm specializing in engineering analysis including Finite Element Analysis (FEA) for stress, thermal, dynamic, buckling, and fatigue. Analyses can be performed for static, dynamic, linear and nonlinear models. DSI also provides Mechanical and Ocean Engineering design services, custom C/C++ programming for engineering applications, and technical software training in using some of these powerful, complex, state of the art engineering tools.

Ted Fryberger, PE, has an MS in Mechanical/Ocean Engineering from the University of California at Berkeley, and a BS in Mechanical Engineering from the Pennsylvania State University. Prior to founding DeepSoft, Inc., he worked as a thermal/stress analyst at the Applied Physics Laboratory of Johns Hopkins University. He holds Professional Engineering licenses in Maryland and Pennsylvania, and is a member of the American Society of Mechanical Engineers, NAFEMS - the worlds only organization of engineering analysts, and the Autodesk Developer Network. He has been selected as an FEA consultant by both Algor, Inc., and Noran Engineering, Inc.; as well as an Autodesk Developer and Consultant by Autodesk, Inc.



Ted Fryberger, PE  
President  
MSME/OE, BSME

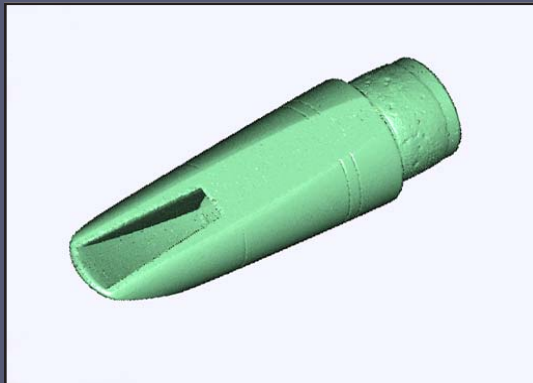

Original Clarinet Mouthpiece  
3D Laser Scan Point Cloud Data

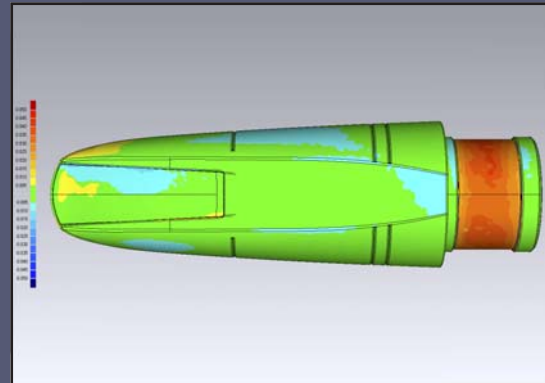

3D Deviation Analysis  
Laser Scan vs New Parametric Solid Model

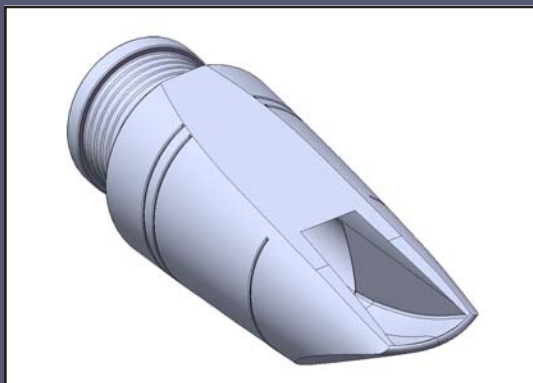

New Clarinet Mouthpiece  
Parametric Solid Model

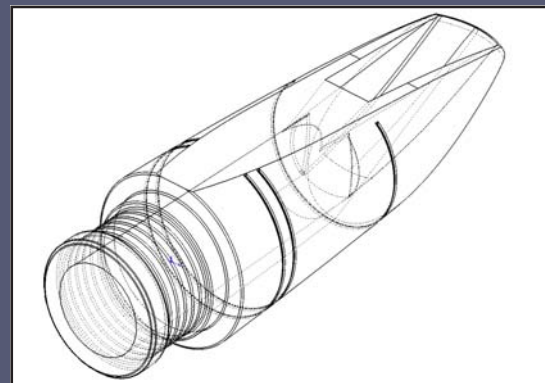

New Clarinet Mouthpiece  
Hidden Line Detail

*DeepSoft, Inc.*

*Engineering Analysis & Design*

6259 Deep River Canyon  
410-312-2982 Phone  
tkf@DeepSoftInc.com

Columbia, MD 21045-2572 USA  
410-312-3067 Fax  
FEA-CAE-Engineering.com